

4

3

2

1

F

F

E

E

D

D

C

C

B

B

A

A

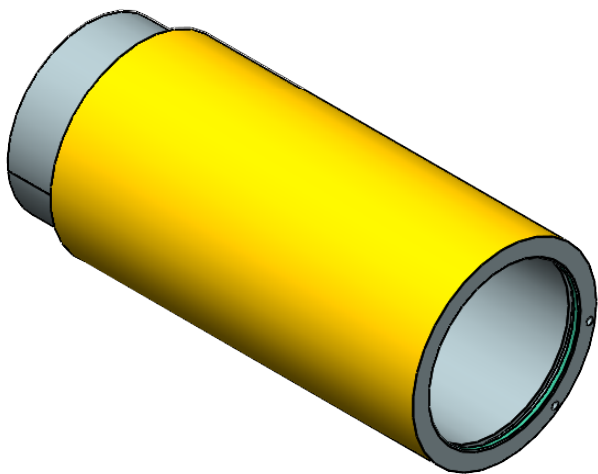
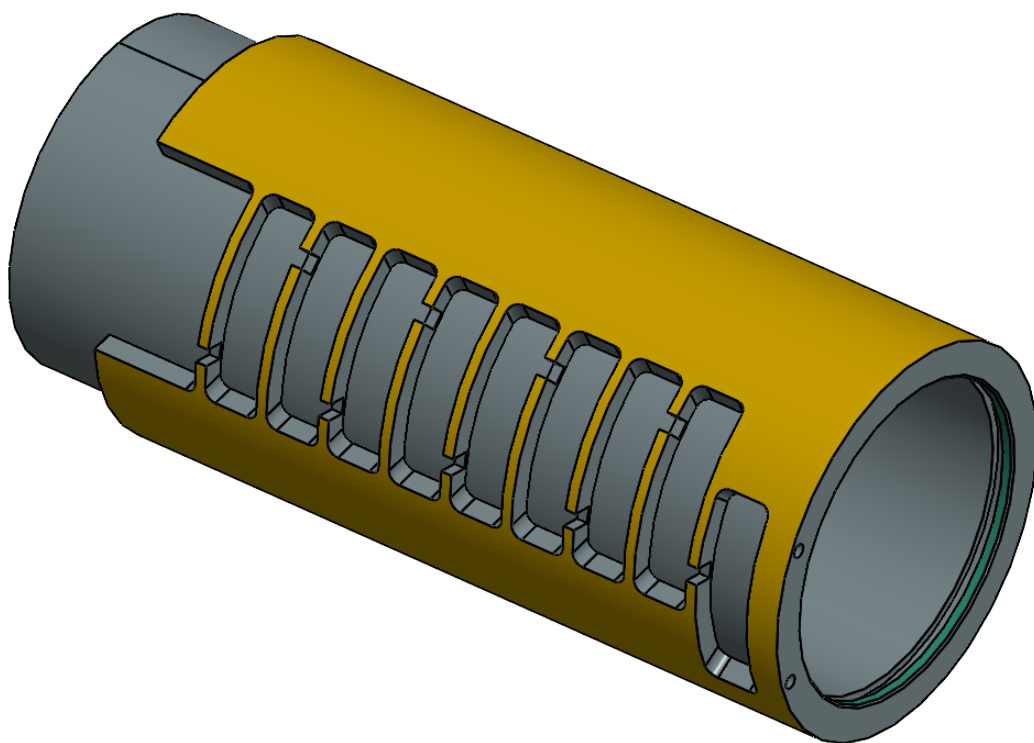

UNLESS OTHERWISE SPECIFIED:
 DIMENSIONS ARE IN MILLIMETERS
 SURFACE FINISH:
 TOLERANCES: ISO2768-M AND ISO 4288
 LINEAR:
 ANGULAR:

FINISH: $\sqrt{3.2}/\sqrt{1.6}$

QTY: 1
 MASS: 20.15KG

DO NOT SCALE DRAWING

REVISION

	NAME	SIGNATURE	DATE
DRAWN	Homayoon.paikani		
CHKD	MR.Kianpoor		
APPVD			
MFG			
Q.A			

TITLE:



**Veera Energy
Pioneers**

MATERIAL:
 STEEL(316L)

DWG NO.

Chamber 3.2

A4

SCALE:1:5

SHEET 1 OF 3

4

3

2

1

4

3

2

1

F

F

E

E

D

D

C

C

B

B

A

A

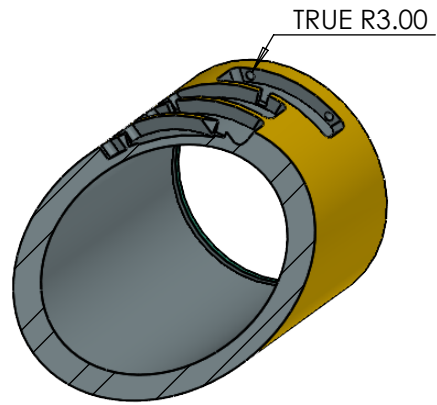
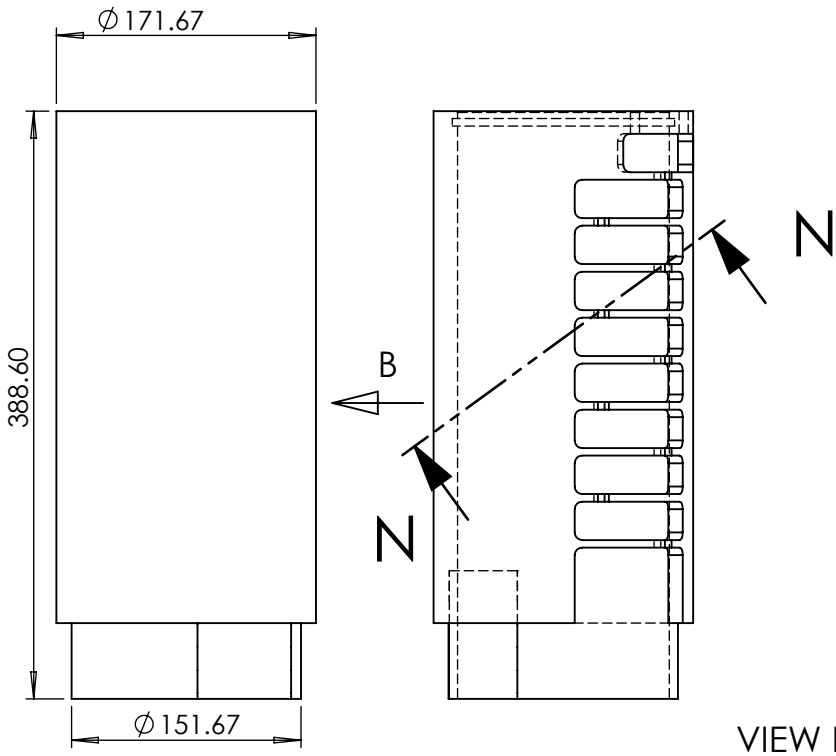
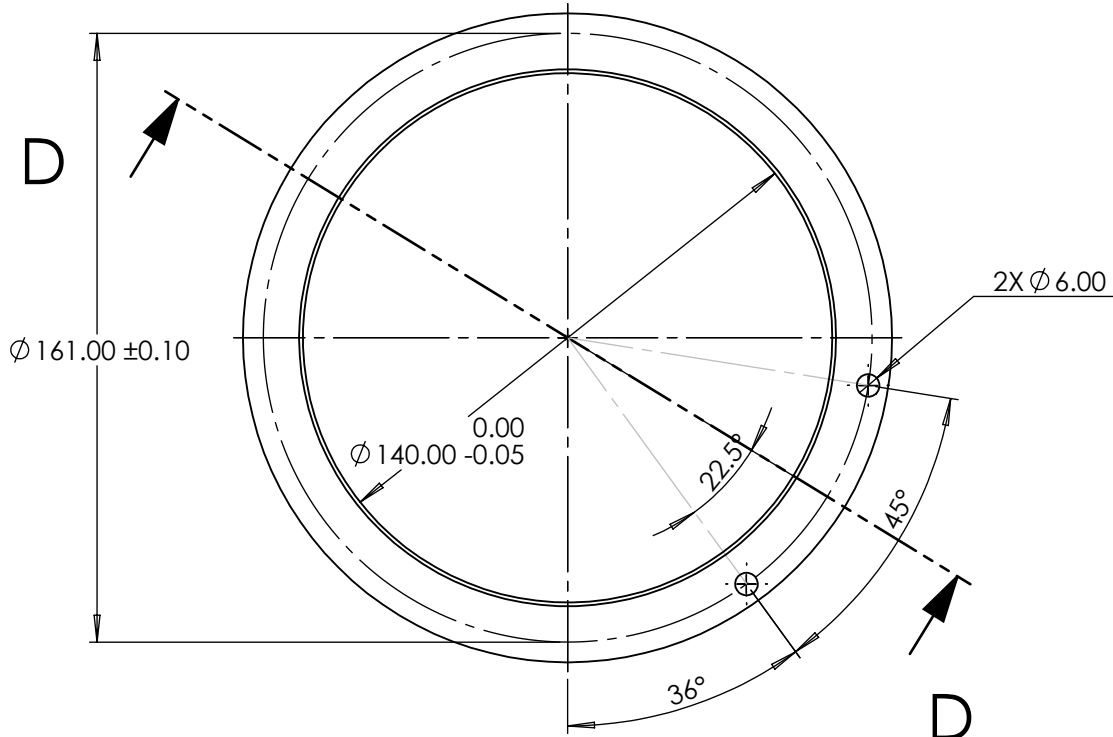

SECTION N-N

UNLESS OTHERWISE SPECIFIED:
 DIMENSIONS ARE IN MILLIMETERS
 SURFACE FINISH:
 TOLERANCES: ISO2768-M AND ISO 4288
 LINEAR:
 ANGULAR:

FINISH: $\sqrt{3.2} / \sqrt{1.6}$

QTY: 1

DO NOT SCALE DRAWING

REVISION

MASS:

	NAME	SIGNATURE	DATE
DRAWN	Homayoon.paikani		
CHKD	MR.Kianpoor		
APPVD			
MFG			
Q.A			

TITLE:



MATERIAL:

STEEL(316L)

DWG NO.

Chamber 3.2

A4

SCALE: 1:5

SHEET 2 OF 3

4

3

2

1

4

3

2

1

F

F

E

E

D

D

C

C

B

B

A

A

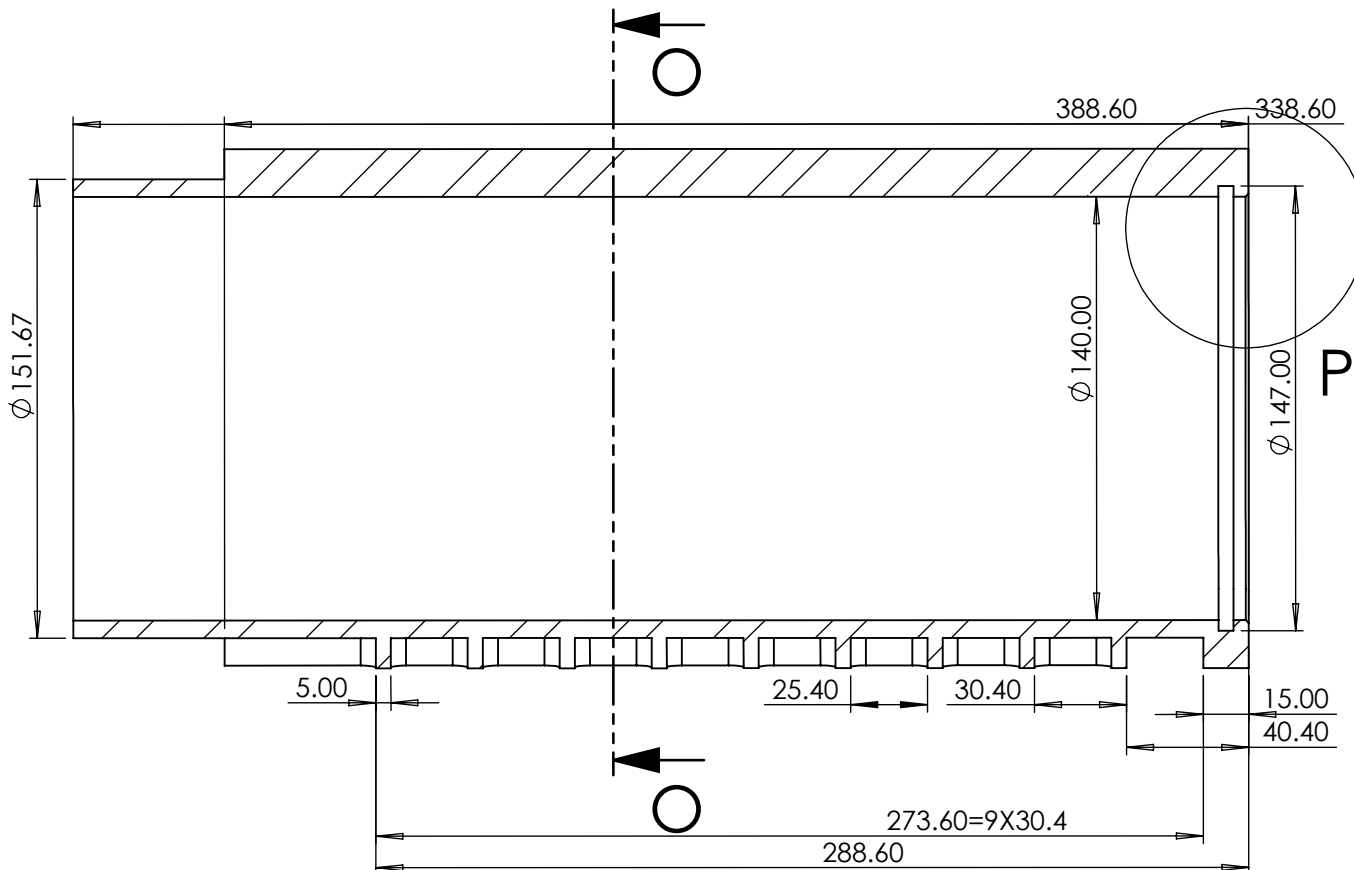

SECTION D-D

SCALE 1 : 2.5

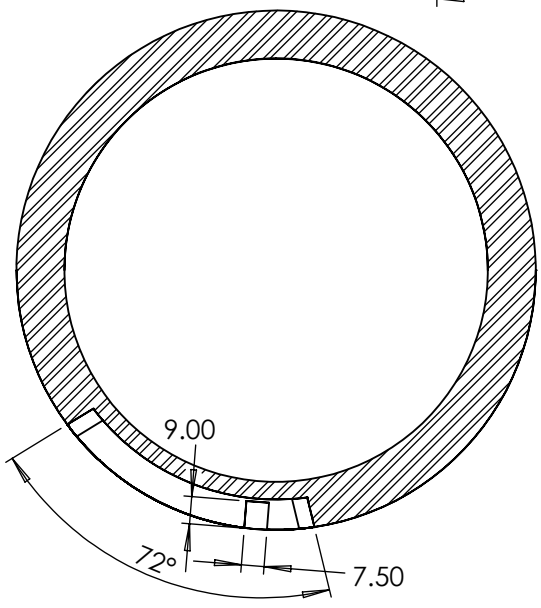

SECTION O-O

SCALE 1 : 2.5

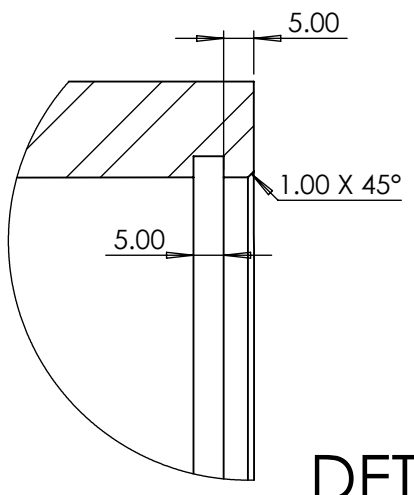

DETAIL P

SCALE 2 : 2.5

UNLESS OTHERWISE SPECIFIED:
DIMENSIONS ARE IN MILLIMETERS
SURFACE FINISH:
TOLERANCES: ISO2768-M AND ISO 4288
LINEAR:
ANGULAR:

FINISH: $\sqrt{3.2} / \sqrt{1.6}$

QTY: 1
MASS:

DO NOT SCALE DRAWING

REVISION

	NAME	SIGNATURE	DATE
DRAWN	Homayoon.paikani		
CHK'D	MR.Kianpoor		
APP'VD			
MFG			
Q.A			

TITLE: 

DWG NO. **Chamber 3.2**

MATERIAL: **STEEL(316L)**

SCALE: 1:5

SHEET 3 OF 3

A4

4

3

2

1