

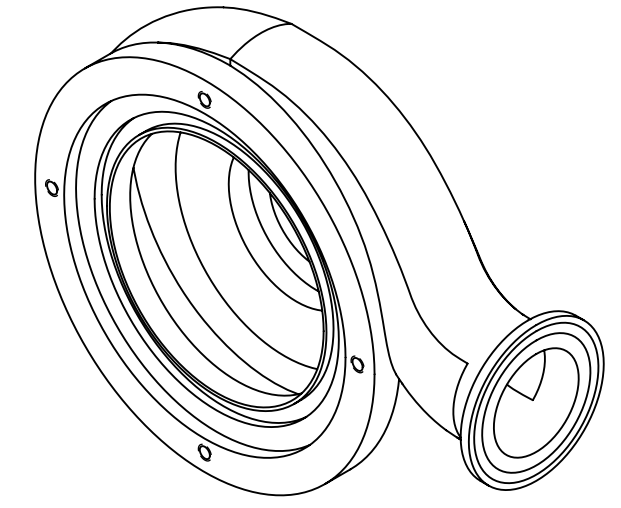

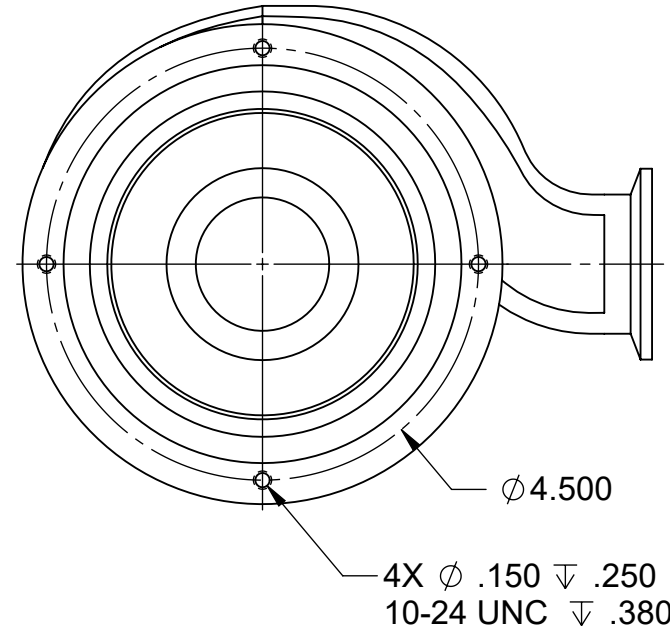

Work in Progress

REVISIONS				
REV.	DESCRIPTION	ECN	DATE	BY
A	INITIAL RELEASE	-	9/13/2024	PJJ



Work in Progress

Work in Progress

MUST BE COMPLIANT TO CURRENT ROHS DIRECTIVE 			
GENERAL TOLERANCES ONE PLACE DECIMAL: $\pm.06$ TWO PLACE DECIMAL: $\pm.03$ THREE PLACE DECIMAL: $\pm.005$ ANGULAR: $\pm 3^\circ$	DRAWN BY	DATE	
	CHECKED BY	DATE	
BREAK SHARP EDGES MUST BE CLEAN AND OIL-FREE	MATERIAL		TITLE
ALL WELDS ARE FUSION WELDS UNLESS OTHERWISE NOTED. THE SYMBOLS USED ON CALLOUTS DEPICT THE SHAPE OF THE JOINT ONLY.	FINISH		
PROPRIETARY AND CONFIDENTIAL THE INFORMATION CONTAINED IN THIS DRAWING IS THE SOLE PROPERTY OF TARK, INC. ANY REPRODUCTION IN PART OR AS A WHOLE WITHOUT THE WRITTEN PERMISSION OF TARK, INC IS PROHIBITED.	 THIRD ANGLE PROJECTION DIM & TOL PER ASME Y14.5M DIMENSIONS ARE IN INCHES		DWG. NO. 318-105
	 THIRD ANGLE PROJECTION DIM & TOL PER ASME Y14.5M DIMENSIONS ARE IN INCHES		REV A
	SHEET SIZE B	SCALE 1:2	SHEET 1 OF 3

Work in Progress

DETAIL PRINT